

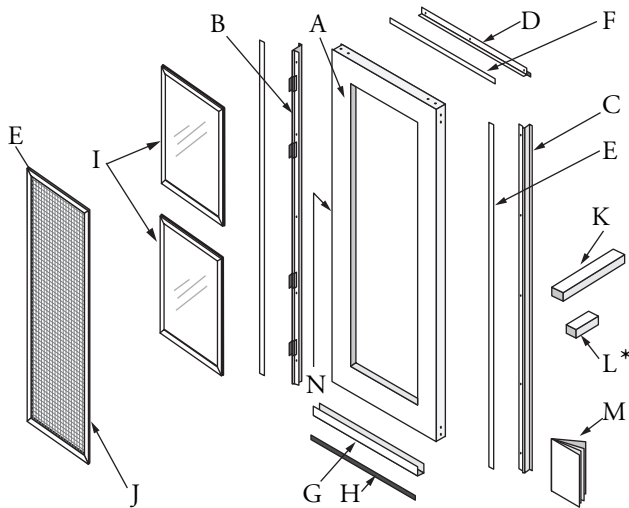

Owner's Manual and Installation Guide PELLA SOLID CORE MODELS with Self Storing Glass and Screen

NOTE TO THE INSTALLER: *This Owner's Manual is the property of the homeowner. Please be sure to leave it with the homeowner upon completion of the installation.*

Door Components





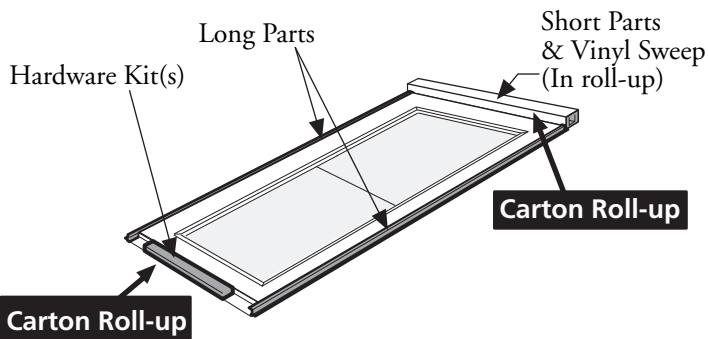





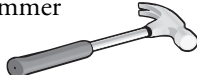



- | | |
|---------------------------|---------------------------------------|
| A. Door Panel | I. Glass (Top and Bottom) |
| B. Hinge Mounting Frame | J. Screen |
| C. Latch Mounting Frame | K. Hardware Kit - Closer |
| D. Top Mounting Frame | L. Handle Kit |
| E. Vertical Screw Cover | * (Some models have one combined kit) |
| F. Horizontal Screw Cover | M. Installation Guide |
| G. Bottom Expander | N. Registration Label |
| H. Sweep (Black Vinyl) | |

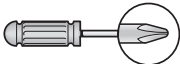

IMPORTANT: Before discarding the carton, make sure ALL parts are accounted for. Check the carton roll-ups at the top and bottom.

Tools Required

- Pencil 
- Hammer 
- Tape measure 
- Hack saw 
- Utility knife or scissors 
- Drill 
- 3/32" drill bit 
- 1/8" drill bit 
- Sawhorses (Optional) 
- Centerpunch 
- Phillips Screwdriver 
- 1/16" to 3/16" shims (Optional) 
- Pliers 
- Power Screwdriver (Optional) 

Installation will require two or more persons for safety reasons.

To order replacement parts, call
1-800-374-4758 or visit us at
www.pella.com.

Please have your registration and model number ready when you contact us either by telephone or on the internet.

REMEMBER TO USE APPROPRIATE PERSONAL PROTECTIVE EQUIPMENT.

TROUBLE SHOOTING GUIDE: Located on back side of this manual

BEFORE YOU BEGIN

- A. Remove the door from the carton.
Note: Before discarding the carton, make sure ALL parts are accounted for. Check the carton roll-ups at the top and bottom.
- B. Record the door's registration number for future reference.
Note: The door's registration label is located on the edge of the door frame.
- C. Determine which side you want your storm door to hinge when viewed from the exterior of your home.

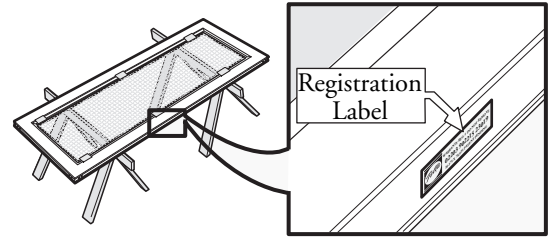

Registration Number:	<input type="text"/>
Door Model Number: <i>(see carton label)</i>	<input type="text"/>

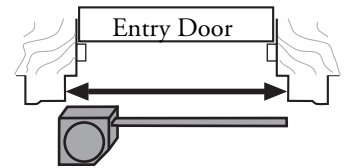

1 ENTRYWAY OPENING PREPARATION

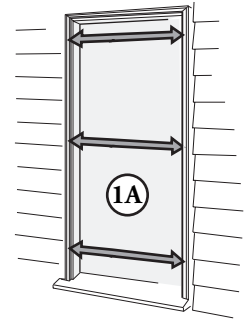

- A. **Verify the door will fit in the entryway opening.** Measure the width of the opening in three locations. Using the smallest measurement, refer to the chart for shimming requirements and shim accordingly.

	<i>Your entryway opening width (measured in inches)</i>			
30" Storm Door	less than 29-7/8	29-7/8 to 30-1/16	Over 30-1/16 to 30-3/8	more than 30-3/8
32" Storm Door	less than 31-7/8	31-7/8 to 32-1/16	Over 32-1/16 to 32-3/8	more than 32-3/8
34" Storm Door	less than 33-7/8	33-7/8 to 34-1/16	Over 34-1/16 to 34-3/8	more than 34-3/8
36" Storm Door	less than 35-7/8	35-7/8 to 36-1/16	Over 36-1/16 to 36-3/8	more than 36-3/8
Shim Requirement →	Custom door size recommended	No shim required	Add shims on the hinge side to get down to the "No shim required" width range.	Custom door size recommended

- B. **If required, shim the entry door frame.** Using four shim sections each about 8" to 12" long, positioned to align with the hinges on the storm door. **DO NOT** extend the shim beyond the face of the entryway.

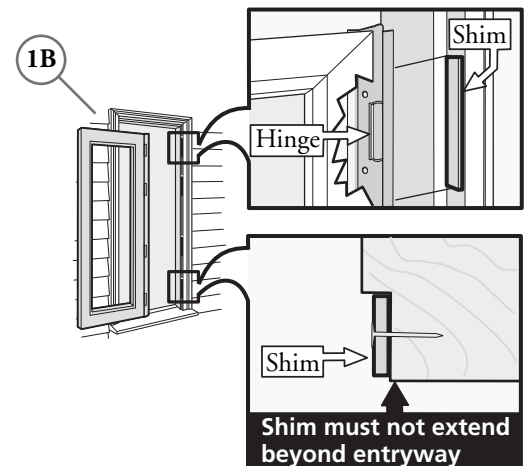

2 GLASS AND SCREEN

Note: See glass and screen section for removal.

3 HINGE MOUNTING FRAME ASSEMBLY

A. **With the interior of the door facing up**, position the hinge mounting frame on the door panel.

Note: Notice the location of the weather-stripping.

B. **Align the pre-drilled hole with the outer hinge hole** and install one hinge screw (#8 x 3/4" hex head).

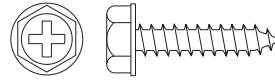

C. **Check to ensure there is a 3/32" overhang** from the highest point of the top of the door.

Note: If the hinge side mounting frame extends more than or less than 3/32" above the top of the door panel, remove the hinge screw. Position the hinge side mounting frame to achieve the 3/32" overhang, and centerpunch and drill a new 1/8" diameter hole through one of the other hinge holes. Install the (#8 x 3/4" hex head) hinge screw in the new hole.

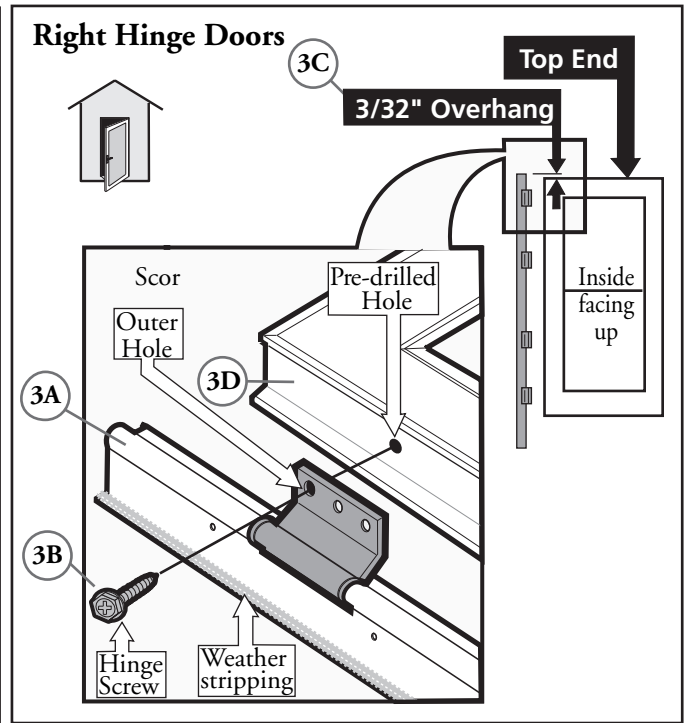
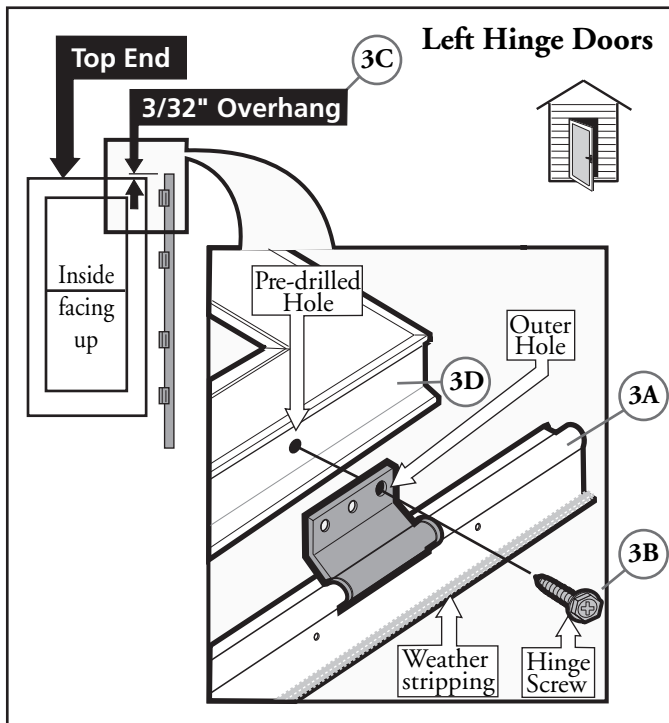
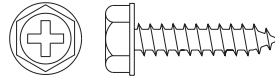

D. **Align the remaining hinges** on the edge of the door, similar to the hinge in 3B.

E. **Centerpunch and drill** the remaining hinge holes using a 1/8" drill bit and install the remaining hinge screws.

F. **Determine the finished length of the mounting frame.** Measure the entryway height in two locations (see L1 and L2) on the side where the storm door hinges will be located and subtract 1/8" from both dimensions.

Note: Measure the entryway with brickmould at the point where the brickmould attaches to the entry door frame.

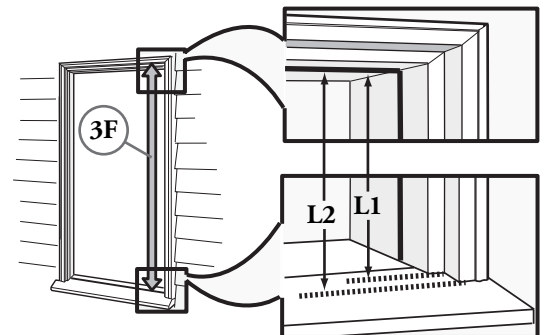

3 HINGE MOUNTING FRAME ASSEMBLY (CONTINUED)

G. Turn the door over so the exterior faces up. Starting at the top of the hinge mounting frame and working toward the bottom, measure and mark the lengths L1 and L2 taken from the previous step.

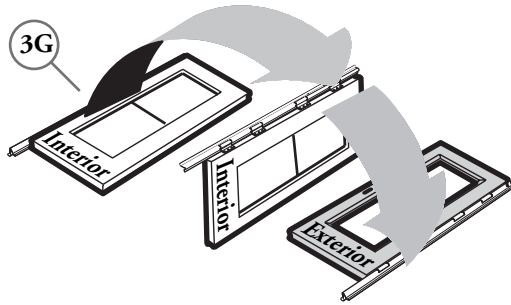

H. Matching the angle of your entryway sill, cut the bottom of the hinge mounting frame to length.

Note: For a simplified installation, a straight cut at L1 may be made. For a more professional looking installation, an angled cut from L1 to L2 may be made.

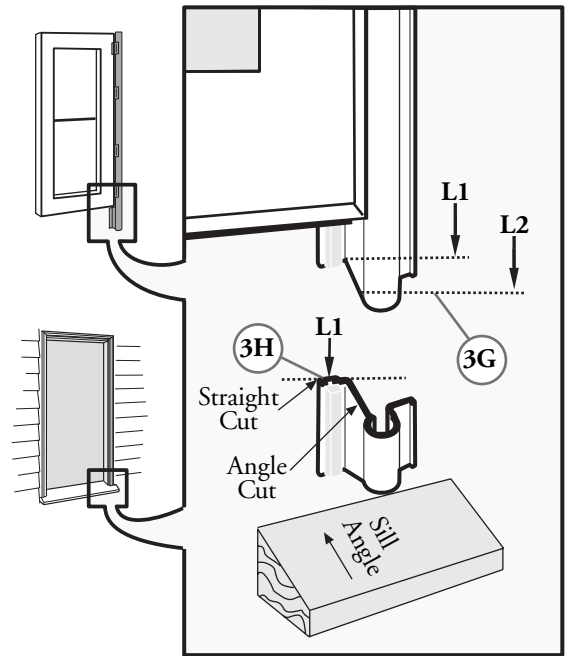

4 BOTTOM EXPANDER ASSEMBLY

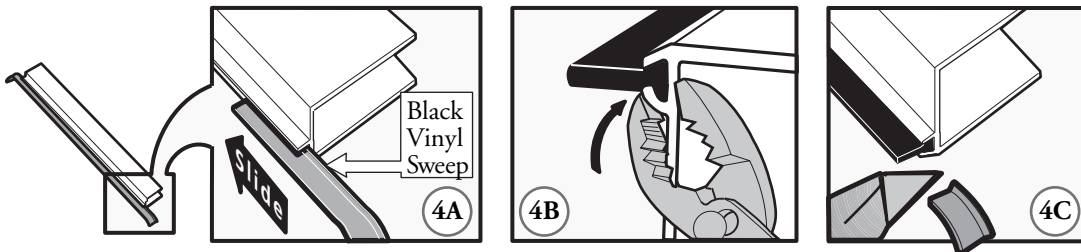

A. Slide the black vinyl sweep along the full length of the bottom expander.

B. Lock the sweep in place by pinching the ends of the inner leg.

C. Cut the excess sweep from each end.

D. Place the bottom expander onto the bottom of the door with the sweep toward the interior. DO NOT install screws in the bottom expander at this time, adjustments are made in a later step.

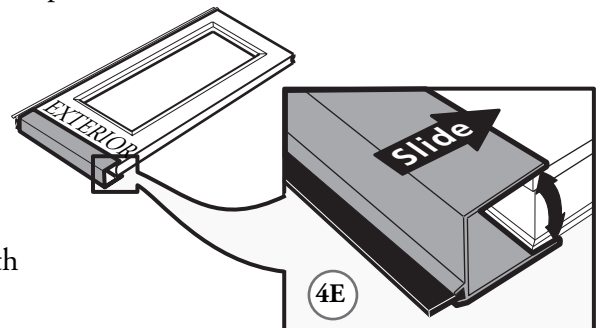

5 TWO OR MORE PEOPLE MAY BE REQUIRED FOR THE FOLLOWING STEPS.

INSTALL THE DOOR

Note: The illustrations show the installation of a left hinge door. Right hinge doors are installed to the right side of the entryway opening

- Set the door in the entryway opening** resting the hinge side mounting frame on the sill. Slide the hinge tight against the entry door jamb or against any shims that were installed in Step 1B.
- Centerpunch and drill a 3/32" diameter hole** through the top pre-drilled hole of the hinge mounting frame. Install a mounting frame screw (#6 x 1" Phillips pan head). Verify the door operates properly.
- Centerpunch and drill a 3/32" diameter hole** through each pre-drilled hole of the hinge mounting frame. Install a mounting frame screw (#6 x 1" Phillips pan head) in each hole. **DO NOT** overtighten.
- Open the door.** Centerpunch and drill a 3/32" diameter hole through each pre-drilled hole of the hinge mounting frame. Install the inside jamb screws (#8 x 3/4" Phillips pan head). **DO NOT** overtighten.

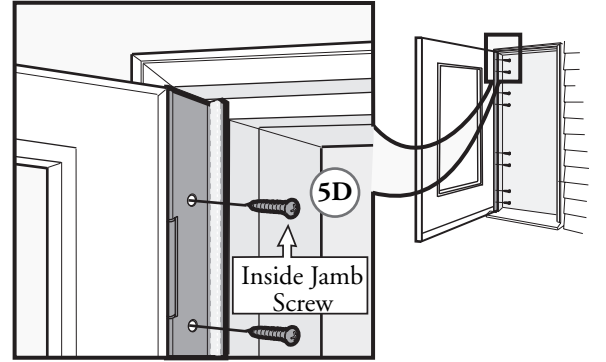
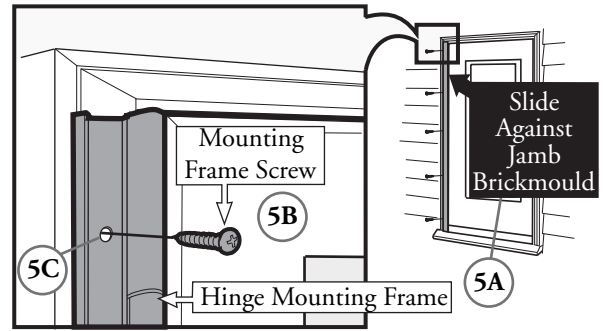

6 TOP MOUNTING FRAME

- With the door open, position the top mounting frame** so it rests on the hinge mounting frame.
- Close the door and align the end** of the top mounting frame with the outer edge of the hinge mounting frame. Position to achieve a uniform gap between the top mounting frame and the door.
- Centerpunch and drill a 3/32" diameter hole** through each pre-drilled hole of the top mounting frame. Install the top mounting frame with the mounting frame screws (#6 x 1" Phillips pan head).

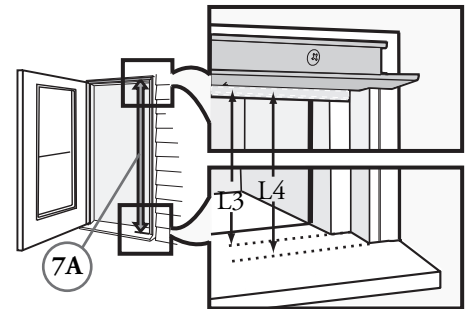
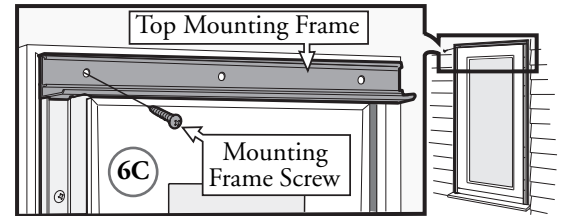

7 LATCH MOUNTING FRAME

- Measure the latch side height** from the underside of the top mounting frame to the sill (see L3 and L4).
Note: Measure entryway with brickmould at the point where the brickmould attaches to the entry door frame.
- Starting at the top of the latch mounting frame, mark off your measurement (see L3 and L4) and cut to length matching the angle of the sill.**
Note: Notice the position of the weather-stripping. Copy the cuts made in step 3H.

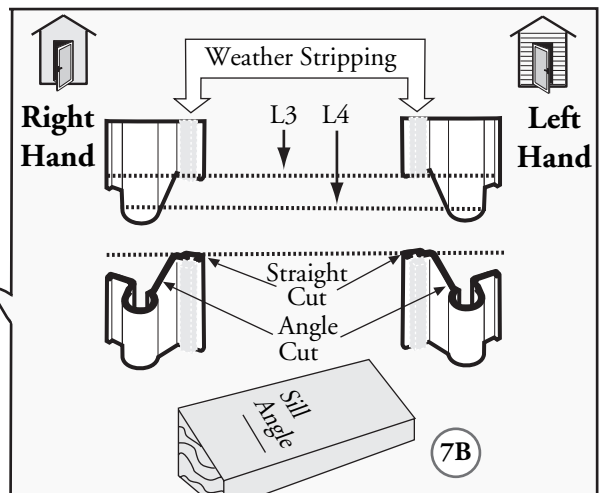

7 LATCH MOUNTING FRAME (Continued)

- C. Position the latch side mounting frame in the entryway opening. Adjust for an even $3/32"$ to $1/8"$ gap between the mounting frame and the storm door. Beginning at the top hole, centerpunch and drill a $3/32"$ diameter hole through each pre-drilled hole of the latch mounting frame. Be sure to keep equal space between the mounting frame and the door panel from top to bottom. Install a mounting frame screw (#6 x 1" Phillips pan head) in each hole.

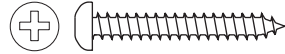

Hint: Drilling and installing the top screw first makes it easier to align the mounting frame correctly.

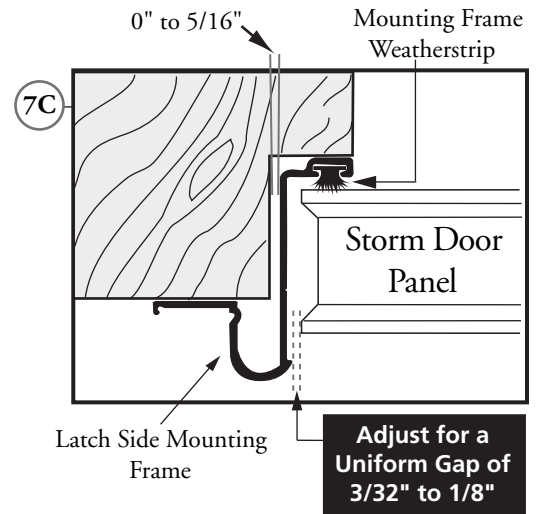

8 BOTTOM EXPANDER ADJUSTMENT

- A. Close the door and adjust the bottom expander so it is centered on the door and the sweep lightly contacts the sill. Remove the protective plastic film from the bottom expander.
- B. From the interior, 4" in and $1/4"$ down, centerpunch and drill a $1/8"$ hole on both ends of the bottom expander. Drill through the bottom expander and interior surface of the door.
- C. Install a bottom expander screw (#6 x $1/2"$ Phillips pan head) in each end. 

Note: Use a hand screwdriver to install the expander screws. DO NOT use a power screwdriver.

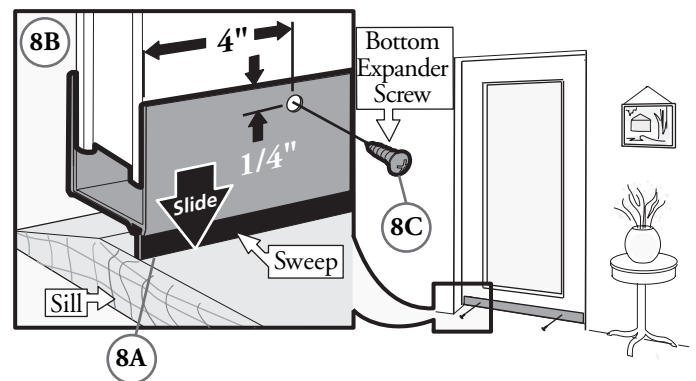

9 DOOR HANDLE HARDWARE

- A. **Handle Hardware:** To install the handle assembly, refer to the separate instruction sheet included in the handle hardware box.

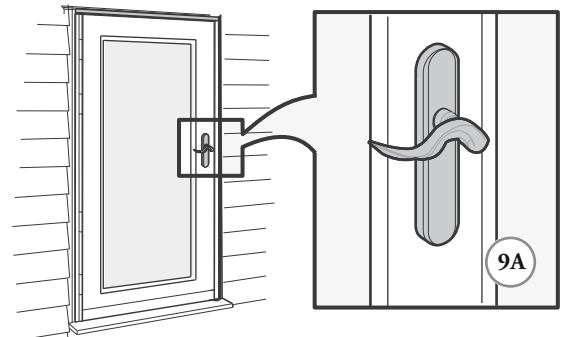

10 DOOR CLOSERS

A. **Top Closer:** Install the jamb closer bracket 1/4" back from the hinge side with the center of the bracket 1" down from the top of the entryway jamb. Mark the screw hole locations and drill 1/8" diameter holes.

B. **Bottom Closer:** On the hinge side of your entryway, position a jamb closer bracket even with the top of the bottom expander, (see the dotted line in the illustration) and 1/4" back from the mounting frame. Mark the screw hole locations and drill 1/8" diameter holes.

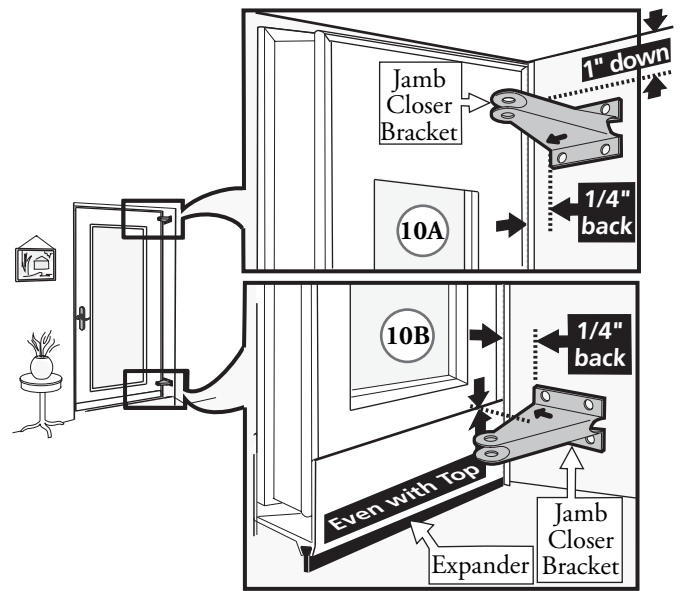

C. **Install the two jamb closer brackets** using four jamb closer bracket screws (#10 x 1" Phillips pan head) for each bracket.

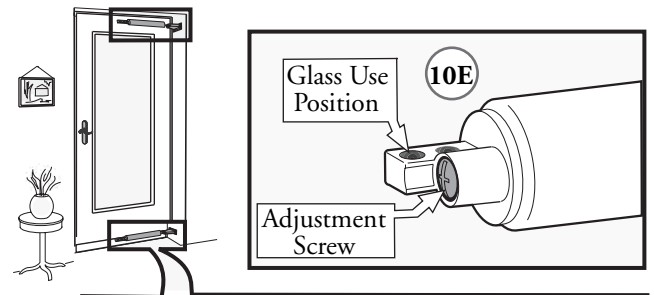
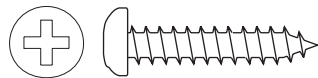

D. **Slide the hold open washer onto the closer rod** and attach the rod to the jamb bracket using the short closer pin.

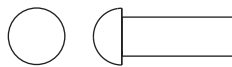

E. **Attach the door closer to the door closer bracket** using the long closer pin in the "glass use" position and turn the adjustment screw, counter clockwise 4 to 5 turns.

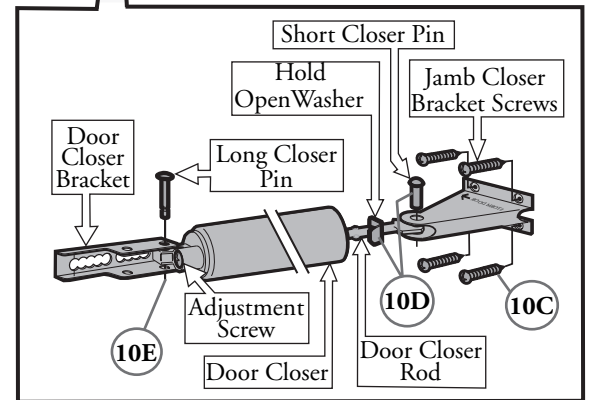
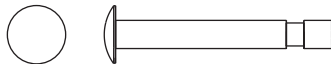

F. **Pull the door closer tube and slide the hold open washer past the lugs.** Adjust the hold open washer to achieve a distance of 1/16" between the hold open washer and the lugs.

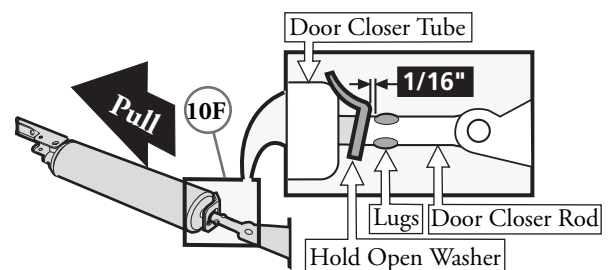

10 DOOR CLOSERS (Continued)

G. **Top door closer bracket.** With the door tightly closed, holding the closer level and position the door closer bracket against the door. Mark the centers of the hole patterns. Centerpunch and drill 1/8" diameter holes through the interior face of the door.

H. **Bottom door closer bracket.** With the door tightly closed, align the top of the door closer bracket with the top of the bottom expander. Mark the centers of the hole patterns. Centerpunch and drill 1/8" diameter holes through the interior face of the door.

I. **Install each door closer bracket** with two door closer bracket screws (#10 x 5/8" Phillips pan head).

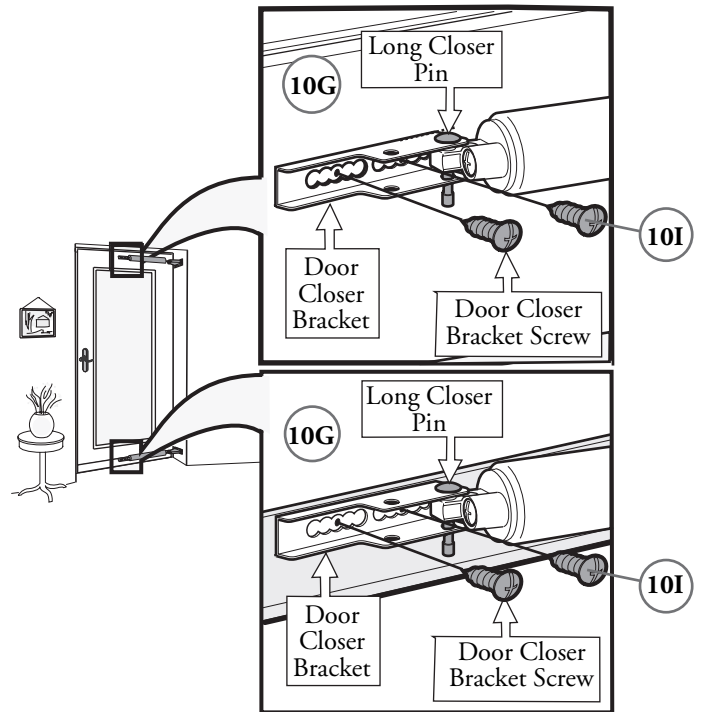
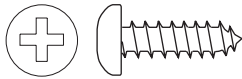

J. **Open the door and check the closer speed.** The speed of the closer may be adjusted by turning the adjustment screw. Turn the screw clockwise to reduce the closer speed or counter clockwise to increase the closer speed.

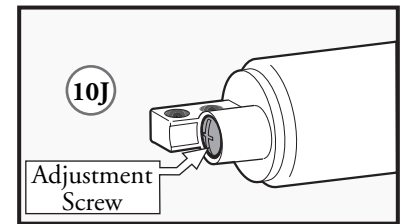

11 EXTERIOR SCREW COVERS

A. **Screw Covers:** Starting flush at one end, install the horizontal screw cover strip by inserting the angled edge into the outer most track and pressing in place. Repeat this procedure for the two vertical screw covers starting at the top of the mounting frames.

Note: Cut the vertical screw covers to match the length of the mounting frame by scoring with a utility knife, then snapping in two.

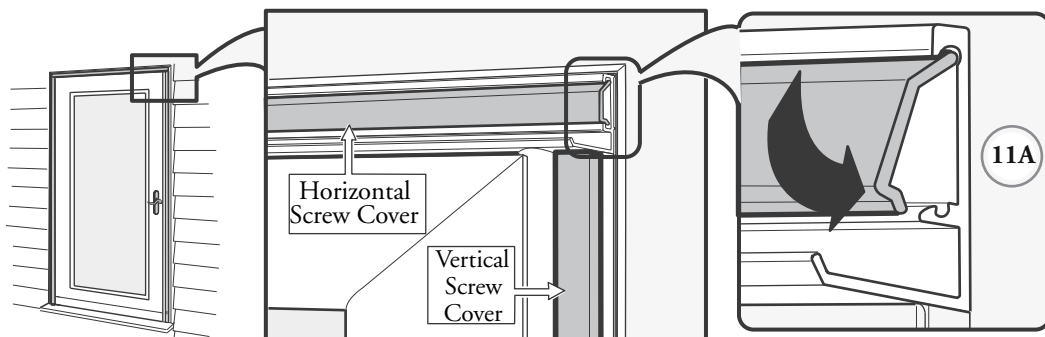

12 SELF-STORING GLASS AND SCREEN OPERATION

- A. To remove the glass, pull the sash locks toward each other. Lift the lower portion of the glass toward you. Pivot the glass sideways and remove it from the door track.
- B. To remove the screen, pull the two screen pins toward each other and lift the screen out of its track.
- C. For weather tight operation, be sure the narrow window panel is in the top position.
- D. For normal operation, experiment with the glass positions to control the ventilation to suit your needs. The upper and lower glass panels can be repositioned or removed to achieve many ventilation options.

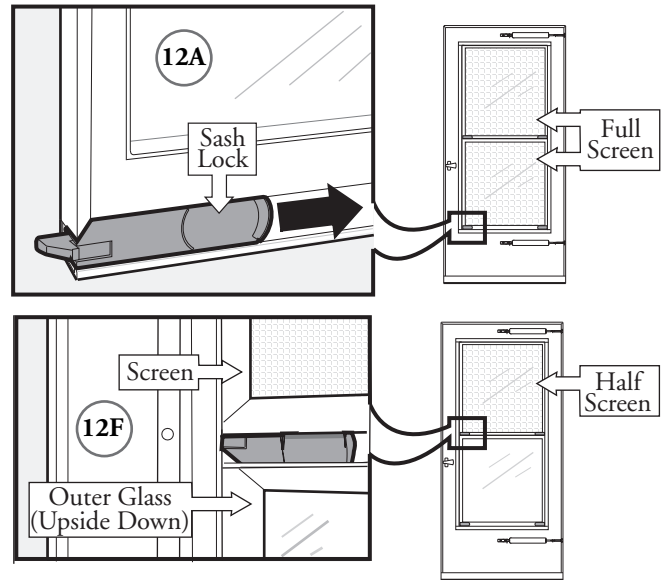

- E. **Models with full screens:** The screen is an integral part of the window system and must be in place for safe and proper operation.
- F. **OPTIONAL top venting for models with half screens only.**
For models with half screens - Place the top (outer) glass panel, in the middle track, upside down and lower to the bottom of the door. Position the screen above this glass panel. Place the inner glass panel in its original track and adjust for ventilation preference.

PLEASE NOTE: The door is not water tight with the screen in this position (at the top). This optional glass/screen position is not recommended for installations without a protective overhang or for winter season use.

13 DECORATIVE GRID OPERATION – If included with your model.

- A. **Grid removal:** If needed, you may remove the grid by lifting the grid up and pivoting the lower portion out of the window opening.
- B. **Grid installation:** place the grid in the outer most track of the door with the decorative edging toward the outside. Start with the top, then lift and set the lower portion in place.

Note: The grid must be in place for proper weather sealing with the glass panels.

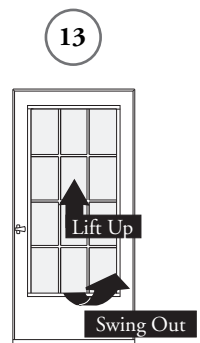

CARE AND MAINTENANCE

PLAIN GLASS CLEANING



Models with decorative glass - follow instructions below.

Note: DO NOT use an ammonia-based cleaner for the first cleaning of the glass.

First Cleaning: Use a mixture of one part vinegar with four parts water to remove the protective coating (applied for shipping protection) from the glass.

Routine Cleaning: Use a soft cloth with a mild soap and water solution, or any household glass cleaner.

DECORATIVE STAINED GLASS CLEANING

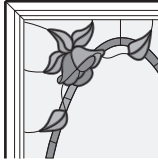

ONE-OF-A-KIND ORIGINALS

The stained glass on your Pella panel is hand crafted. Slight imperfections or variation of color are normal. No two glass panels are exactly alike.

Routine Cleaning: Use a soft cloth with a mild soap and water solution, or any glass cleaner.

DECORATIVE BRASS CAMING CLEANING

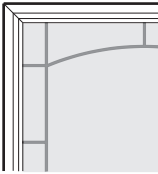

The glass is hand crafted with brass caming.

To clean and polish the brass, use a brass polish such as Brasso® or a leading brass cleaner. Follow the product's directions and carefully wipe down the brass caming. Be sure to wipe all of the cleaner from the glass. Use a toothbrush to carefully remove any cleaner from between the brass edges and the glass. Cleaning may also be done by using #0000 steel wool. Carefully rub down the brass with light even strokes - avoid touching the glass with the steel wool.

DOOR CLEANING



Routine Cleaning: Painted metal surfaces of the door may be cleaned by using a soft cloth with a mild soap and water solution, or any household grease-cutting cleaner.

Note: Light marks on the painted surfaces of the door can be removed using turpentine or any household grease-cutting cleaner.

BOTTOM EXPANDER CLEANING

IMPORTANT: DO NOT use brass polish or steel wool on the bottom expander.

The bottom expander is an aluminum product with a simulated metallic anodized finish.

Use a soft cloth with a mild soap and water solution or any household grease-cutting cleaner.

BRASS & OTHER METALLIC HANDLE CLEANING

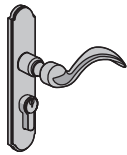

Routine Cleaning: Use a soft cloth with a mild soap and water solution to clean the surfaces. Apply a high quality, non-abrasive automobile wax to polish.

Note: DO NOT use ammonia-based cleaners on brass or other metallic finish handles.

CLEANING & REFINISHING DAMAGED BRASS

If your Pella door comes packaged with a brass handle; the brass has been polished and sealed with a clear coating by the manufacturer. Should the finish be accidentally damaged by an abrasive or sharp object, it will succumb to a natural oxidation process that occurs when the elements contact unprotected brass. Brass has an enduring quality, in that it can be refurbished to its original polished finish again and again by using a quality brass polish such as Brasso and a soft cloth.

1. Remove the hardware from the door so the finish of the door will not be affected. See the hardware instructions for removal.
Note: You may be able to leave the hardware in place on the door when polishing the handle. Make certain to completely mask off all areas around the handle before starting. If polishing the key cylinder, protect the internal mechanism by covering the opening with tape.
2. Use a quality brass polish to clean the brass - follow the product manufacturer's directions.
Note: Firm rubbing may be necessary to loosen the coating on the brass.
3. Reseal the brass using one of the following methods:
 - a. Apply a coat of high quality, non-abrasive, polymer-based automobile wax - follow the product manufacturer's directions.
 - b. Apply a clear coat lacquer spray to the brass - follow the product manufacturer's directions.**Note: If you removed the hardware from the door, lubricate any internal workings with a spray lubricant. Re-install the hardware on the door using the hardware installation instructions.**

TROUBLE SHOOTING GUIDE

If you have a question that you don't see listed here, or, haven't been able to resolve through the use of your Pella Owner's Manual and Installation Instruction, call one of our customer service representatives toll-free at 1-800-374-4758.

Common Questions	Probable Causes	Suggested Solutions
Door doesn't open/close properly.	Entryway opening out of square/plumb or frame warped.	<ul style="list-style-type: none"> • Verify the opening and shim to square as necessary.
	Closer out of position.	<ul style="list-style-type: none"> • Remove the adjustment screw from the closers and cycle the door a few times, then replace the screw and adjust for proper speed. Disconnect the other closer from the door, to adjust one closer at a time. • Verify the arrow on the jamb bracket is pointing toward the storm door - if not, reverse the bracket • Adjust the position of the closer door bracket until the door closes properly
	Closer pin in the screen use position	<ul style="list-style-type: none"> • Move closer pin to the glass use position. (See steps 10D and 10Q).
	Bottom expander out of position.	<ul style="list-style-type: none"> • Verify the expander is centered on the door - adjust as necessary. • Verify the expander is not too low - raise the expander up so the sweep just contacts the sill.
	Top mounting frame out of alignment.	<ul style="list-style-type: none"> • Verify top mounting frame weather stripping is positioned between the latch and hinge mounting frames and not overlapping.
	Hinges binding.	<ul style="list-style-type: none"> • Verify mounting frame screws are not overtightened - back off screws slightly. • Verify entryway framing is not twisted or warped - shim or modify as necessary. • Verify hinge mounting frame is not twisted or bent - replace if necessary.
Handle doesn't latch properly	Latch not hitting strike plate.	<ul style="list-style-type: none"> • Adjust the strike plate so the latch catches properly - add shims as necessary.
	Lockbody upside down (mortise hardware)	<ul style="list-style-type: none"> • Verify the live bolt is above the deadbolt and the live bolt is positioned correctly - see hardware installation sheet for proper placement.
	Closer out of position.	<ul style="list-style-type: none"> • See "Closer out of position" in the "Door doesn't open/close properly" question above.
Water between the storm door and entry door.	The bottom sweep is making a tight seal against the door sill.	<ul style="list-style-type: none"> • Open the storm door and notch up to 1/2" off both the latch and hinge end of the vinyl sweep strip.
	Weep holes clogged.	<ul style="list-style-type: none"> • Check the bottom window insert track and exterior drainage hole openings for obstructions.

Note: DO NOT cut down the door panel. Cutting down the door panel will void the warranty.

PELLA® STORM DOORS LIMITED WARRANTY - Effective April 1, 2000

Congratulations on choosing a Pella storm door to protect and beautify your home. This superior quality door has been designed to give you years of trouble-free service, and you are protected by this limited warranty:

Pella warrants to the ORIGINAL HOMEOWNER PURCHASER of this storm door that it will, without charge to the purchaser, repair or exchange, at its option, any door determined to be defective in material or workmanship for 20 years after the purchase date. The purchaser will be responsible for transporting the door to and from the nearest Pella storm door dealer. Should the door be determined to be defective in material or workmanship AFTER 20 years from the purchase date, the original purchaser may buy one new Pella storm door at 50% of the then-current manufacturer's suggested list price for as long as the original purchaser owns the home on which the door was installed. The purchase must be made directly from the factory, and all transportation charges are the responsibility of the purchaser.

Should the door be determined to be defective and the purchaser incurs a reinstallation cost within three years of the purchase date, he or she may be reimbursed for these costs up to a maximum of \$25.00, upon furnishing a copy of the invoice for the reinstallation costs.

As a condition of this warranty, it is required that the door be used for residential use only in an owner-occupied home, that it be installed properly as an operating door according to manufacturer's instructions, and that it not be altered in any way. For multi-unit housing applications, ask your dealer for a copy of the appropriate warranty or phone Pella's Customer Service Department at the phone number listed below. This warranty is not transferable.

To make a claim under this warranty, you should:

- Call our Customer Service Department at 1-888-646-5354 or write to Pella Warranty Service; 2288 University Avenue; St. Paul, MN 55114 USA.
- Furnish the original or a copy of the sales receipt or other documents showing the original purchase date and that you are the original purchaser of this door. Exchange is limited to supplying a replacement door of comparable size, style, and original color and does not include any cost of removal or installation except as noted above.

We will do our best to contact you within seven (7) days after your inquiry reaches us.

The warranty on the latch set and air closer is one year, and any labor charges are not covered. This warranty excludes all damage to glass and screen. This warranty does not cover problems caused by improper storage, handling, installation, use, modification, or maintenance, by Acts of God or by accidents, including accidental glass breakage. It does not apply to normal wear or discoloration of finish; finish problems caused by mechanical damage or abrasion; normal effects of sun and weather, including acid rain, salt spray, or other corrosive elements; damage caused by severe wind; or damage caused by customer abuse or neglect. Brass handle set is guaranteed not to tarnish and carries a lifetime finish warranty for as long as the purchaser owns their home.

THIS WARRANTY EXCLUDES ALL INCIDENTAL AND CONSEQUENTIAL DAMAGES. Nothing in this document shall give rise to or extend the period of any warranties implied under state or provincial law, and no implied warranty shall extend beyond the periods covered by this written warranty. Neither Pella Corporation nor any seller of Pella products will be responsible for incidental or consequential damages which may result from a product defect or malfunction. Some states do not allow the exclusion or limitation of incidental or consequential damages, so the above limitation or exclusion may not apply to you. This warranty gives you specific legal rights, and you may have additional rights which vary from state to state.

